

hohem | iSteady **MT3** ^{Pro}

User Manual v 1.0

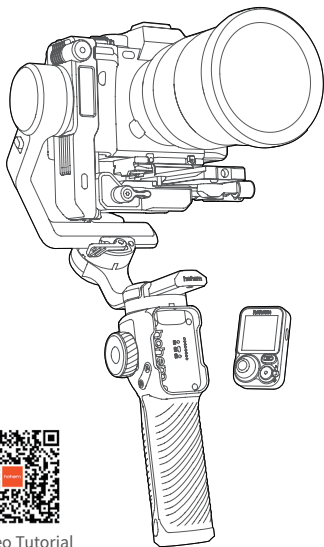

▶ Video Tutorial

Contents

1	Package Contents	01
2	Meet iSteady MT3 Pro	02
3	Charging	04
3.1	Charging Method	04
3.2	Charging Display	05
3.3	Reverse Charging	06
4	First Use	08
4.1	Preparation	08
4.2	Mounting a Camera	10
4.3	Mounting a Smartphone	16
4.4	Mounting an Action Camera	17
4.5	Balancing	21
4.6	Powering On/Off	26
4.7	Calibration	26
4.8	Firmware Update	29
5	Basic Operation	29
5.1	Connecting to the Devices	29
5.2	Buttons	33
5.3	Ports	37
5.4	Indicators	39
5.5	Touchscreen Remote	40
5.6	Working Modes	47
6	AI Tracking	50
6.1	Touchscreen Control	51

6.2	Button Control	52
6.3	Gesture Control	54
6.4	Live Feed Image Calibration	56
6.5	Indicators	56
7	Hohem Joy App	57
7.1	Downloading	57
7.2	Gimbal Connection	57
7.3	Camera Interface	57
7.4	Gimbal Control	61
8	Specifications	66
9	Safety Guidelines	69
10	Compliance Information	71

1 Package Contents

Before use, ensure that all items listed below are included in the package. If any item is missing, please contact Hohem or your local distributor.



Gimbal



Tripod



Quick-Release Plate Kit
(Arca-Swiss)



Phone Clamp



Action Camera Adapter



Camera Fixing Screw
(2 pcs)



Charging Cable
(USB-A to USB-C)



Camera Control Cable
(USB-C)



Camera Control Cable
(Sony Multi)



Hex Key



Lens Support



Thumb Screw Knob



Documents

2 Meet iSteady MT3 Pro

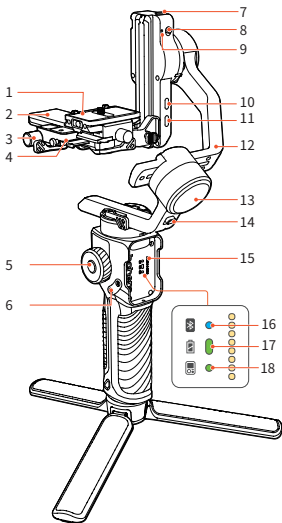

1. Upper Quick-Release Plate (Arca-Swiss)
2. Lower Quick-Release Plate (Arca-Swiss)
3. Fine-Tuning Knob
4. Camera Mounting Base
5. Side Roller
6. A-B Button
7. 1/4"-20 UNC Port
8. AI Camera Switch
9. AI Camera Status Indicator
10. Reverse Charging Port(USB-C)
11. Focus Motor Port
12. Roll Arm
13. Roll Motor
14. Roll Lock
15. Pogo Pins
16. Bluetooth Indicator
17. Gimbal Battery Indicator
18. Remote Connection Indicator

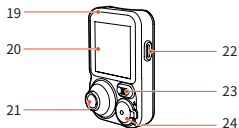

- 19. Live Feed Remote
- 20. 1.4-Inch Full-Color Touchscreen
- 21. Joystick
- 22. Side Button
- 23. M (Mode) Button
- 24. Zoom Lever & Shutter Button

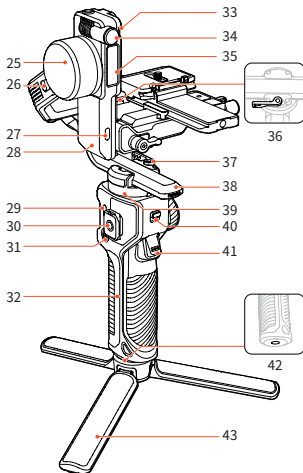

- 25. Tilt Motor
- 26. Tilt Lock
- 27. Camera Control Port (USB-C)
- 28. Tilt Arm
- 29. Charging Port (USB-C)
- 30. NATO Port
- 31. Power Button
- 32. Handle
- 33. AI Camera Status Indicator
- 34. Built-in AI Camera
- 35. Built-in Fill Light
- 36. Roll Lever
- 37. Pan Lever
- 38. Pan Arm
- 39. Pan Motor
- 40. Pan Lock
- 41. Trigger
- 42. 1/4"-20 UNC Port
- 43. Tripod

3 Charging

Please fully charge the gimbal before using it for the first time.

The gimbal includes two USB-C ⚡ ports.

The port on the handle is for charging the gimbal.

The port on the tilt arm provides power output.

3.1 Charging Method

Connect the included USB-A to USB-C charging cable from the "IN" port on the gimbal handle to a USB power adapter for charging.*

*It is recommended to use a 5V-3A USB charger(not included).

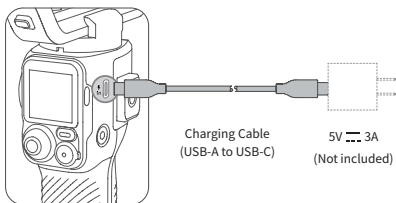

3.2 Charging Display

You can check the current battery level via the battery icon on the touchscreen or the battery indicator on the handle.

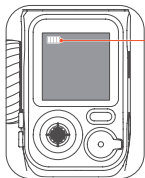

Gimbal Battery Icon:

 <100%

 <75%

 <50%

 <25%

 Shutting down soon

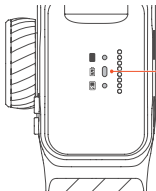

Gimbal Battery Indicator:

 Solid green 50%–99% or fully charged

 Solid yellow 25%–49%

 Solid red <25%

 Blinks red quickly Shutting down soon

When the gimbal is powered off, you can still check the battery status by pressing the power button once. The screen will display the current battery levels of the gimbal.

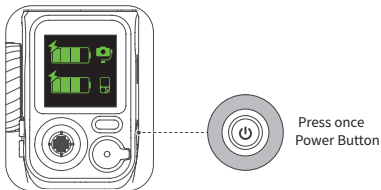

3.3 Reverse Charging

To use the gimbal as a power bank:

1. Connect your device to the reverse charging port.
2. The gimbal will automatically start charging when it is powered on or in standby mode.
3. Charging is not available when the gimbal is completely powered off.

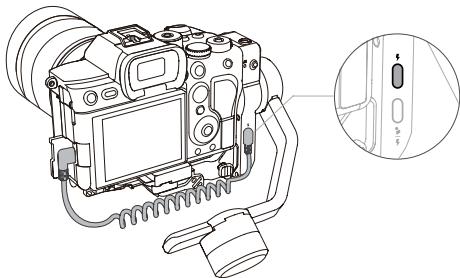

*Using iSteady MT3 Pro to charge your camera or phone will reduce the runtime of your gimbal.

4 First Use

4.1 Preparation

1. Attach the tripod to the bottom of the handle. Unfold it and place the gimbal on a flat, stable surface.

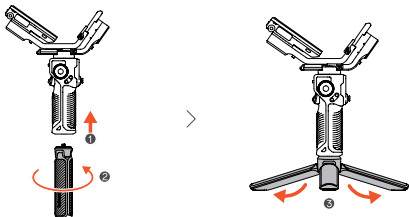

2. The gimbal is packaged in the locked position. Toggle the tilt and roll locks to the unlocked position respectively and adjust the position of both axes as shown in the figure below, then lock the axes.

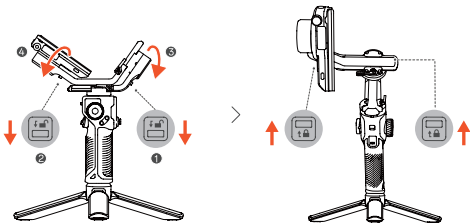

- Loosen the knob on the camera mounting base. While pressing the safety lock, slide the camera mounting base into the gimbal and tighten the knob.

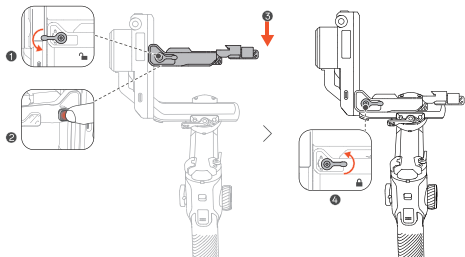

4.2 Mounting a Camera

It is recommended to watch all the tutorial videos for the first time.



▶ Video Tutorial

Supported Cameras and Lenses

Make sure the combined weight of the camera, lens, and other accessories are within the load capacity.

Refer to the [iSteady MT Series Compatibility List](#) for compatible camera lenses and control features supported.



iSteady MT Series
Compatibility List

Horizontal Shooting

1. Loosen the knob on the lower quick-release plate, then remove the upper quick-release plate.

Then, unfold the anti-deflection baffle.

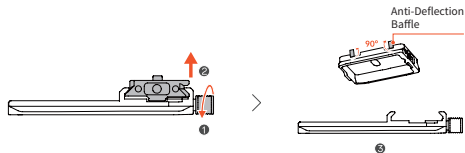

- Attach the upper quick-release plate to the bottom of the camera with the provided camera fixing screw, ensuring it is firmly fixed. Ensure the camera sits flush against the anti-deflection baffle to prevent forward slippage.

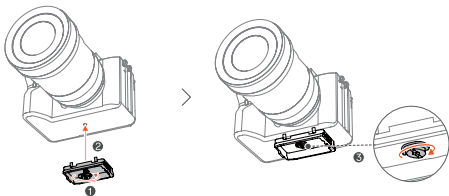

- Insert the upper quick-release plate (with the camera attached) into the lower quick-release plate along the rail until it clicks into place. Tighten the knob after the whole set is engaged.

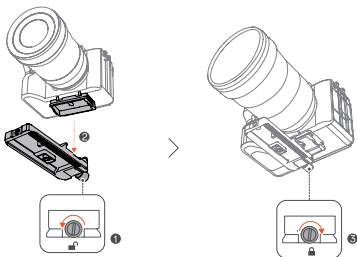

4. Unlock the lower lever on the camera mounting base, extend it to match the width of your camera, then lock the lever to secure it in place.

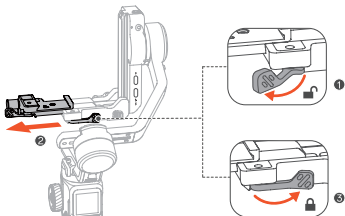

5. Unlock the upper lever on the camera mounting base. While pressing the safety lock, insert the lower quick-release plate into the camera mounting base. Then, lock the upper lever to secure it.

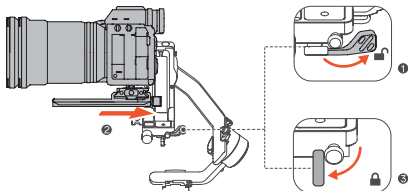

Vertical Shooting

1. Loosen the knob on the camera mounting base and press the safety lock, then remove the camera mounting base.

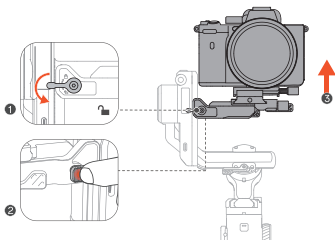

2. After rotating it 90 degrees, mount it vertically onto the gimbal and tighten the knob.

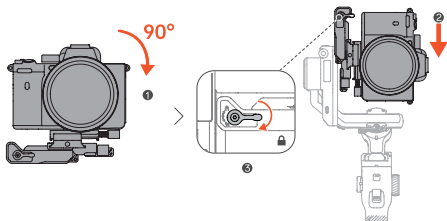

Lens Support

It is recommended to use the lens support when using a long or heavy lens to provide extra stability for your lens.

Mount the provided lens support onto the camera base, and adjust the height until it lightly touches the lens. Then tighten the screw to lock it in place.

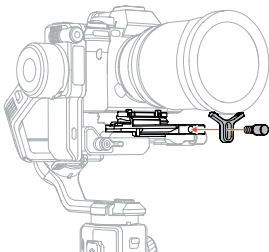

Temporarily Removing the Camera

If you need to replace the camera battery, change the lens or accessories, temporarily remove the camera.

With the gimbal powered off or in Standby Mode*, loosen the knob on the lower quick-release plate and remove the camera together with the upper quick-release plate.

*In Standby Mode, all three axes are paused while the gimbal remains powered on. To enter Standby Mode, double-press the power button. Double press the power button again to exit Standby Mode.

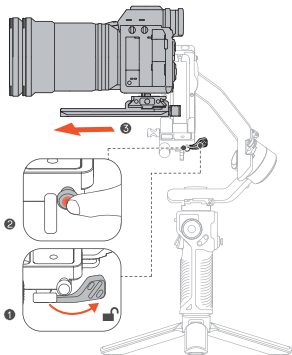

Readjust the balance of each axis when switching between horizontal shooting mode and vertical shooting mode, or changing the lens or accessories.

4.3 Mounting a Smartphone

Horizontal Shooting

1. Expand the phone clamp to fit your phone's width, then attach it to the device. Ensure the phone is snug against the rubber pads of the clamp.

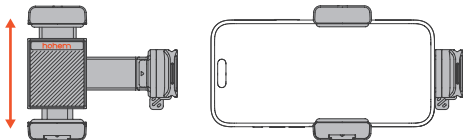

2. Unlock the lever on the phone clamp. While pressing the safety lock, insert the phone clamp onto the gimbal and lock the lever.

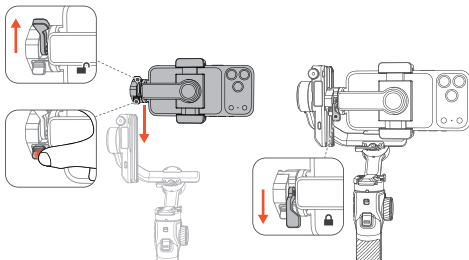

Vertical Shooting

Remove the phone, rotate the phone clamp 90°, then place the phone back into the clamp.

*The phone clamp features a cold shoe mount and a 1/4"-20 UNC Port, allowing accessories to be mounted. Rotate the clamp clockwise or counterclockwise, ensuring that the accessory mount faces outward.

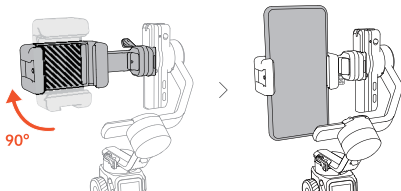

4.4 Mounting an Action Camera

Horizontal Shooting

1. Mount the action camera onto the upper quick-release plate using the finger adapter and thumbscrew.

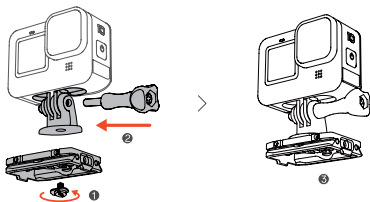

- Loosen the knob on the lower quick-release plate and insert the upper quick-release plate (with the camera attached) into the lower quick-release plate along the rail until it clicks into place. Tighten the knob after the whole set is engaged.

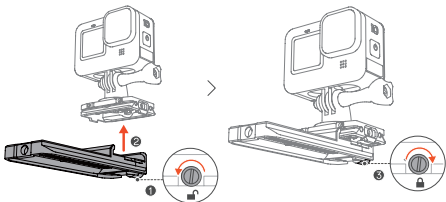

- Unlock the lower lever on the camera mounting base, extend it to match the width of the camera, then lock the lever to secure it in place.

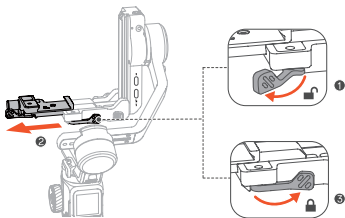

- Unlock the upper lever on the camera mounting base. While pressing the safety lock, insert the lower quick-release plate into the camera mounting base. Then, lock the upper lever to secure it.

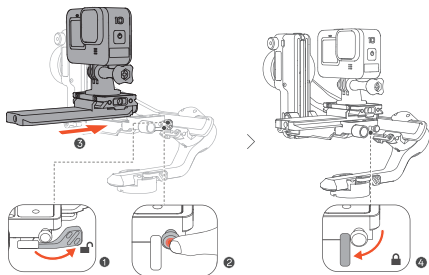

Vertical Shooting

1. Loosen the knob on the camera mounting base and press the safety lock, then remove the camera mounting base.

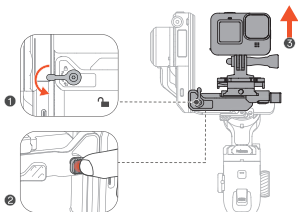

2. After rotating it 90 degrees, mount it vertically onto the gimbal and tighten the knob.

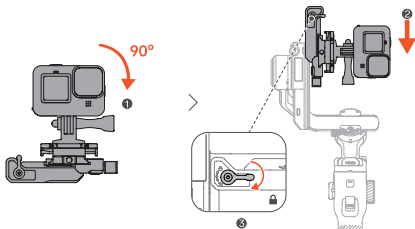

4.5 Balancing

Before using the gimbal, balance the tilt axis, roll axis, and pan axis in sequence according to your shooting needs. This ensures stable footage and optimal gimbal performance.

It is recommended to watch all the tutorial videos for the first time.



 Video Tutorial

Tips

Here we take the camera as an example. The steps to balance the phone or action camera are basically the same.



- Readjust the balance of each axis when switching between horizontal shooting mode and vertical shooting mode, or changing the lens or accessories.
- Before balancing, power on the camera and set the lens to your commonly used focal length. Then proceed with the subsequent balancing steps.

Tilt Axis Balancing

Vertical Balancing of the Tilt Axis

1. Unlock the tilt axis.
2. Rotate the tilt axis to make the camera lens point upward. Check to make sure the camera is not left or right-heavy:
 - If left heavy, move the camera right.
 - If right-heavy, move the camera left.

Loosen the mounting base knob and move the mounting base left and right to adjust the center of gravity.

3. The vertical tilt is balanced when the camera is steady while pointing upward. Once balanced, tighten the knob to secure it.

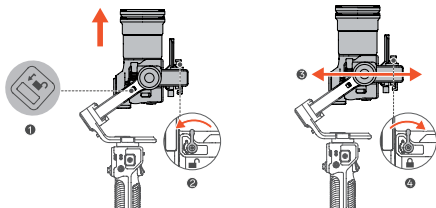

Horizontal Balancing of the Tilt Axis

1. Rotate the tilt axis to make the camera lens point forward.
2. Check to make sure the camera is not front or back-heavy:
 - If it is front-heavy, turn the knob clockwise to move the camera backward.
 - If it is back-heavy, turn the knob counterclockwise to move the camera forward.

Unlock the upper lever on the camera mounting base and move the quick-release plate back and forth to adjust the center of gravity.

3. Once the camera stays level on its own, the tilt axis is considered balanced. Lock the upper lever on the camera mounting base, then lock the tilt axis.

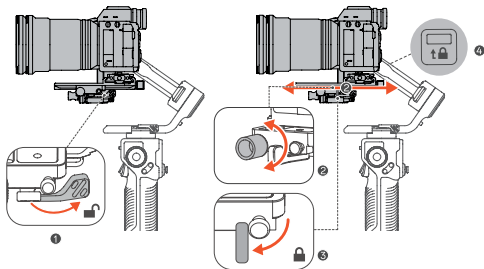

Roll Axis Balancing

1. Unlock the roll axis .
2. Check the direction in which the roll motor swings:
 - If the camera rotates to the left, move the camera to the right.
 - If the camera rotates to the right, move the camera to the left.
 Unlock the roll lever, lightly move the roll arm left and right to adjust the center of gravity.
3. The roll axis is balanced when the camera remains level. Tighten the roll arm lever and lock the roll axis to complete this step.

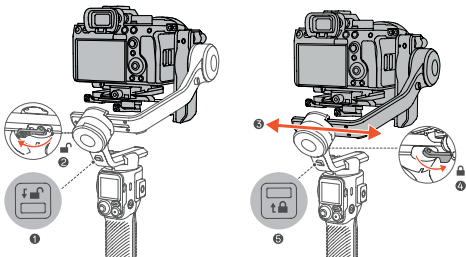

Pan Axis Balancing

1. Unlock the pan axis.
2. While holding the handle, tilt the gimbal forward and rotate the pan arm until it is parallel with your body. Check the pan axis movement:
 - If the camera lens rotates to the left, move the pan arm to the right.
 - If the camera lens rotates to the right, move the pan arm to the left.Unlock the pan lever and slide the pan arm left and right to adjust the center of gravity.
3. The pan axis is balanced when the camera remains steady while rotating the pan with the handle tilted. Move the lever on the pan arm to the locked position.

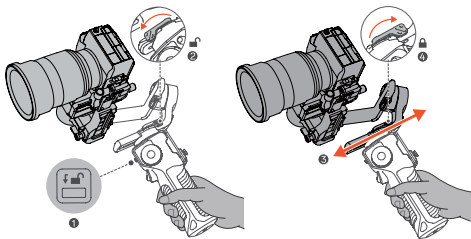

Tips

After balancing is complete, unlock all three axes before powering on the gimbal.

4.6 Powering On/Off

Make sure that the gimbal is balanced and that all three locks are unlocked before powering on the gimbal.

Press and hold for 3 seconds: Power on/off

Press twice: Enter Standby mode (Press twice again to exit it)

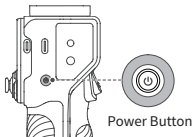

If vibration occurs after powering on once balancing is complete, perform a motor calibration. For detailed instructions, refer to Section [4.7 Calibration](#).

4.7 Calibration

To ensure optimal stabilization performance and accurate horizon alignment under different loads and usage conditions, perform the following calibrations as needed.

Symptom	Action
Vibration, shaking, or motor noise	Perform Motor Calibration
Image tilted	Perform Level Calibration

Before Calibration

- Ensure the gimbal is properly balanced on all three axes.
- Place the gimbal on a stable, level surface.
- Do not touch or move the gimbal during calibration.

Motor Calibration

Motor calibration is recommended if the gimbal vibrates at startup, or produces abnormal motor noise.

1. Turn on the gimbal and put it on a hard, flat surface.
2. From the touchscreen home screen, enter the M. Strength interface. The three values represent the motor strength of each axis.
3. Tap Auto Calibration to allow the gimbal to calibrate automatically.
4. Alternatively, tap an axis to adjust the motor strength manually as needed.



Level Calibration

Perform level calibration if the image appears tilted or remains off-level despite proper mechanical balancing.

1. Turn on the gimbal and place it on a firm, level surface.
2. Tap the trigger twice to recenter the gimbal.
3. From the touchscreen, enter the More Settings interface.

4. Select Level Calibration.
 - a. Under Manual, view the current drift angle of each axis and perform manual calibration as needed.
 - b. Alternatively, tap Auto Calibration to allow the gimbal to calibrate automatically.
5. You can also quickly start Auto Calibration by pressing the M button five times in quick succession.
6. A single "beep" indicates that the calibration is complete.

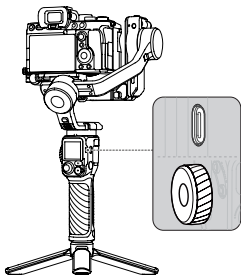

Tips

- Do not perform calibration unless the gimbal is placed on a stable, flat surface. For example, do not calibrate while holding it in a car. Calibration in an unstable position may fail.
- If calibration fails: You will hear two "beep" sounds, indicating the gimbal has entered standby mode. Double-tap the power button to wake the gimbal. Repeat the calibration steps as described above.

4.8 Firmware Update

You will be prompted in the Hohem Joy App if a new firmware update is available. Follow the on-screen instructions to update firmware.

5 Basic Operation

5.1 Connecting to the Devices

The iSteady MT3 Pro is compatible with cameras, smartphones, and action cameras. It supports Bluetooth control for these three types of devices and can also control cameras via a data cable. Refer to the iSteady MT Series Compatibility List for control features and compatible camera lenses supported.

Bluetooth Control

1. Connecting Your Camera with Bluetooth

On Your Camera

(The menu options may vary on different camera models. Here we take Sony α7R IV as an example.)

Make sure that your device is in pairing mode, and then follow these steps on your camera:

- Go to [Menu] - [Network] - [Bluetooth Settings] - [Bluetooth Function] - [On].
- Select [Bluetooth Settings] - [Pairing].
- Your camera will find all available devices. Tap "MT3PCam-XXXXXX" to start pairing.

On Your Gimbal

- Slide down the touchscreen to access the Bluetooth Connection interface.

- b. Tap [Camera] - [Confirm] to find your device.
- c. When your device name appears in the list, tap [Select], tap [Confirm] to complete the pairing.
- d. To reset, tap [Reset] - [Reset] - [Confirm]. A pop-up "Bluetooth connection already reset" will confirm the disconnection.

2. Connecting Your Action Camera with Bluetooth

On Your Action Camera

(The menu options may vary on different camera models. Here we take GoPro HERO13 Black as an example.)

Make sure that your device is in pairing mode, and then follow these steps on your GoPro:

- a. Swipe down on the rear screen to access the Dashboard, and then swipe left to add devices.
- b. Tap Pair Device. Your GoPro will automatically start searching for compatible devices.
- c. Your GoPro will find all available devices. Tap "MT3P-XXXXXX" to start pairing.

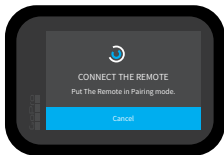

On Your Gimbal

- a. Slide down the touchscreen to access the Bluetooth Connection interface.
- b. Tap [Camera] - [Confirm] to find your device.

- c. When your device name appears in the list, tap [Select], tap [Confirm] to complete the pairing.
- d. To reset, tap [Reset] - [Reset] - [Confirm]. A pop-up "Bluetooth connection already reset" will confirm the disconnection.

3. Connect to Your Phone with Bluetooth

- a. With your gimbal on, go to the Bluetooth settings on your phone and select "MT3P-XXXXXX" from the list of devices.
- b. Follow the on-screen instructions to connect and pair.
- c. Press the side roller or the side button seven times in quick succession. When the  Bluetooth icon in the touchscreen status bar changes to , the Bluetooth connection has been successfully reset.

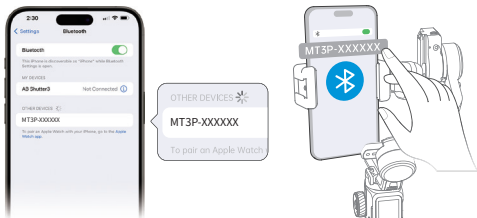

Wired Control

Use the camera control cable to connect the camera control port on the gimbal to the USB port on the camera.

For detailed information on the cables used by the camera and their supported functions, refer to the [iSteady MT Series Compatibility List](#).



iSteady MT Series
Compatibility List

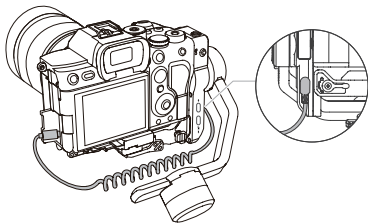

Two camera control cables are included in the package: a USB-C to USB-C Camera Control Cable and a Sony Multi Camera Control Cable.

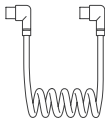

Camera Control
Cable (USB-C)

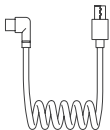

Camera Control
Cable (Sony Multi)

5.2 Buttons



Power Button

Press and hold for 3s: Power on/off the gimbal

Press twice: Enter Standby mode(Press twice again to exit it)

Press once when your gimbal is off: Check the battery level

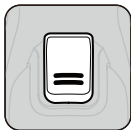

Trigger

Tap once: Pause/resume AI tracking*

Tap twice: Recenter the gimbal

Tap three times: Rotate pan motor position 180°

Press and hold: Switch to Sport (S) mode

Tap once, then press and hold: Temporarily switch to All Lock (L) mode (release the trigger to return to the original mode)

* For more information, refer to [6 AI Tracking](#).

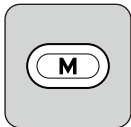

M (Mode) Button

Press once: Switch between working modes

Press three times: Switch to Inception mode

Press five times: Auto level calibration

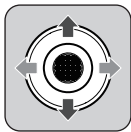

Joystick

Push up/down: Tilt up/down

Push left/right: Pan left/right



Side Button

Press once: Pause/resume AI tracking^[1]

Press twice: Recenter the gimbal

Press three times: Rotate pan motor position 180°

Press and hold: Live Feed Image Calibration

Press five times: Pair the gimbal with the remote controller^[2]

Press seven times: Clear the remote connection

1. For more information, refer to [6 AI Tracking](#).
 2. To pair the gimbal with the remote controller, press the side roller on the gimbal five times and press the side button on the remote controller five times.
-

All Zoom lever/shutter button features require a Bluetooth/wired connection to your camera or phone.



Zoom Lever

Lever up/down: Zoom in/out*

*Zoom control compatibility varies by device. On smartphones, zoom control is available only when using the Hohem Joy app. For cameras, a lens that supports electronic zoom is required. Zoom control is not supported for action cameras.

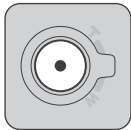

Shutter Button

Shutter control requires your device to be connected to the gimbal, either via Bluetooth or a wired control cable. For detailed instructions, refer to [5.1 Connecting to the Devices](#).

Available shutter control functions vary by device type and model. Refer to the [iSteady MT Series Compatibility List](#) for more details.

Camera Mounted

Half press: Auto focus

Press once: Start or stop recording video

Press and hold for 1s: Take a photo

*On some camera models, photo/video mode switching must be performed directly on the camera. Please refer to the camera compatibility list for details.

Smartphone Mounted

Press once: Start or stop recording video or take a photo

Press twice: Switch between video and photo modes*

Press three times: Switch between front and rear camera*

*Requires the Hohem Joy app when used with a smartphone.

Action Camera* Mounted

Press once: Start or stop recording video or take a photo

Press twice: Switch between video and photo modes

*The gimbal's shutter button supports shooting control on selected action cameras, including GoPro from HERO 8 onward. Shutter control on other brands or models may be limited. Please refer to the camera compatibility list for details.

Side Roller

The side roller is a multi-function roller and button. Press the wheel to select a function and roll to make adjustments.

Press roller five times: Pair the gimbal with the remote controller*

Press roller seven times: Clear the mobile device Bluetooth connection

*To pair the gimbal with the remote controller, press the side roller on the gimbal five times and press the side button on the remote controller five times.

Focus Control + Axis Rotation

Press twice: Cycle between focus control and axis rotation

Fill Light Control

Press and hold the roller: Turn fill light on or off

Press the roller once: Toggle between brightness and color temperature control

Press three times: Switch between CCT and RGB modes

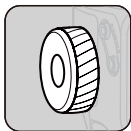

A-B Button

Set the starting and ending point for track shooting or time-lapse footage along a designated path.

*This function should be used separately from the time-lapse feature in the Hohem Joy app.

Setting position A: Move the camera angle with the joystick to the start point, position A and long press Button A to set. A short beep means successful setting.

Setting position B: Move the camera angle with the joystick to the end point, position B and long press Button B to set. A short beep means successful setting.



A-B motion: Single press button A to return to position A from the current position, and then double press Button B to start A-B motion at a constant speed.

B-A motion: Single press button B to return to position B from the current position, and then double press Button A to start B-A motion at a constant speed.

*Duration by default: 1 minute.

5.3 Ports



Charging Port (USB-C)

For charging the gimbal.

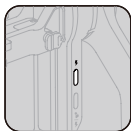

Reverse Charging Port (USB-C)

For powering the mounted device.



Focus Motor Port

For connecting the Hohem Spot Mini Motor.

*Included in the iSteady MT3 Pro Kit version only. Also available for purchase separately.



Camera Control Port (USB-C)

For connecting the camera.

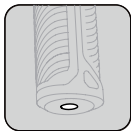

1/4"-20 UNC Port

For attaching external accessories such as a tripod, microphone, or LED light.

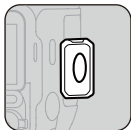

NATO Ports

For connecting the accessories, such as the Hohem Bi-Directional Twist Handle.



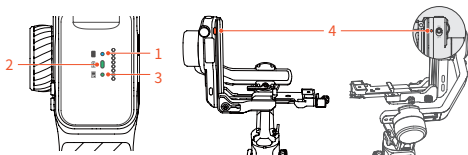

*Included in the iSteady MT3 Pro Kit version only. Also available for purchase separately.

5.4 Indicators







After removing the touchscreen controller, three indicator lights are visible. From top to bottom, they indicate the following: Bluetooth indicator, gimbal battery level indicator, and remote connection indicator.

1. Bluetooth Indicator

	Solid blue	Bluetooth connected
	Blinks blue quickly three times	Bluetooth disconnecting
	Off	Bluetooth disconnected
	Pulse blue	Firmware updating



2. Gimbal Battery Indicator

	Solid green	50%–99% or fully charged
	Solid yellow	25%–49%
	Solid red	<25%
	Blinks red quickly	Shutting down soon

3. Remote Connection Indicator

	Solid green	Remote connected
	Off	Remote disconnected
	Blinks red and green alternately	Remote connecting
	Solid red	Firmware anomaly
	Pulse red	Gimbal overloading
	Pulse yellow	Standby mode

4. AI Camera Status Indicator

	Solid green	AI tracking is active
	Solid red	AI tracking is paused
	Blinks green quickly	Custom composition is in progress

5.5 Touchscreen Remote

When attached to the gimbal, the remote control automatically powers on and pairs once the gimbal is on. The gimbal also charges the remote during this time.

If detached from the gimbal, the remote needs to be powered on separately. It will automatically pair with the gimbal upon powering on.

Interface Status Bar

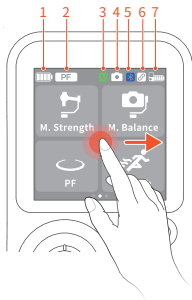

1. Gimbal Battery Level



Battery level <100%



Battery level <75%



Battery level <50%







Battery level <25%



Shutting down soon

2. Working Mode

	Pan Follow Mode	Pan axis is active
	Pan and Tilt Follow Mode	Both Pan and Tilt axes are active
	Point of View Mode	All three axes (Roll, Tilt, and Pan) are active
	Customized Follow Mode	Enable or disable the follow mode for each axis as needed
	Standby Mode	All three axes are paused while the gimbal is still powered on



3. AI Tracking

	AI Tracking is active
	AI Tracking is paused

4. Camera Connection

	Bluetooth connected
	Wired connected

5. Smartphone Connection

	Bluetooth connected
	Bluetooth disconnected

6. Remote Connection

	Touchscreen Remote is connected
---	---------------------------------

7. Remote Controller Battery



<100%



<75%



<50%



<25%



Shutting down soon

Home

On this interface, you can adjust the motor strength, check the motor balance, and select the gimbal working mode and follow speed.



1. M. Strength

The three values represent the motor strength of each axis. Tap an axis to adjust it manually as needed, or tap Auto Calibration to allow the gimbal to calibrate automatically.

2. M. Balance

When the status bar appears green, the gimbal is properly balanced. A yellow status bar indicates a slight imbalance, while a red status bar indicates a critical imbalance. If the status bar turns red, readjust the balance of the corresponding axis.

3. Working Mode Switch

PF, PTF, POV, or Custom modes can be selected via the touchscreen. For more details, refer to [5.6 Working Modes](#).

4. Follow Speed

Tap to set the follow speed and response mode. Follow speed options include Slow, Medium, Fast, and Custom, while response modes include Smooth and Tight.

Slide Right

View the AI Camera live feed on the remote touchscreen. Use touch control to select a subject for tracking. For more information, refer to [6 AI Tracking](#).



Slide Left

From this interface, you can configure the roller function, adjust AI tracking parameters, access scenario creation templates, and open additional gimbal settings.



1. Roller Ctrl

Tap to assign the function of the side roller. The side roller can be set to control roll or pan axis rotation, or to adjust the fill light's CCT or RGB. From this interface, you can also manually turn the light on or off and fine-tune its parameters.

2. AI Settings

From this interface, you can adjust the AI Tracking follow speed, enable or disable tilt tracking, and customize the AI Tracking gesture controls.

3. Scenario

The iSteady MT3 Pro offers four creative scenario shooting modes: Auto Rotation, Panorama, Timelapse, and A/B Point Shooting. Tap to adjust the parameters as needed.

4. More Set

Item	Description
Language	Supports multiple languages, including Simplified Chinese and English.
Tutorial	Scan the QR code to access the user manual and tutorials.
Joystick	The joystick is used to control tilt and pan axis rotation. In this interface, you can adjust the rotation speed and direction.
Gimbal Sound	Enable to turn on/off the gimbal sound.
Level Calibration	Perform auto level calibration or manual calibration if the gimbal is unlevel or an axis is drifting.
Device Info	Tap to view device information, including the device serial number (SN) and name.
Firmware Version	Tap to view the current firmware version. For firmware updates, refer to 4.7 Calibration .

Slide Down

In this interface, you can check the current Bluetooth connection status between the gimbal and your device, as well as connect or disconnect as needed. For more details, refer to [5.1 Connecting to the Devices](#).

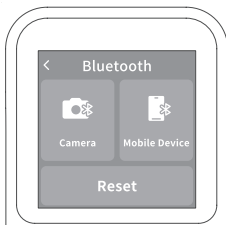

5.6 Working Modes

iSteady MT3 Pro includes three axes of rotation: pan, tilt, and roll axes. The collaborative work between different axes results in the creation of 4 operation modes, each tailored to specific filming needs:

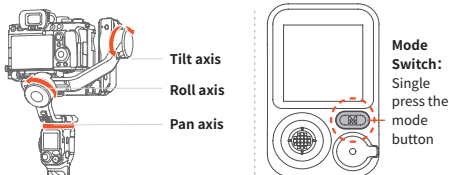

Pan Follow (PF)

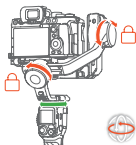

The gimbal follows the pan movement of the handle, while the tilt and roll axes stay stable.

Suitable for smooth horizontal tracking shots, such as following a moving subject or panning landscapes.

Pan and Tilt Follow (PTF)

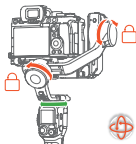

The gimbal follows both pan and tilt movements of the handle, while the roll axis stays stable.

Suitable for shots requiring smooth camera movement in both horizontal and vertical directions, e.g., capturing moving subjects with dynamic angles.

Point of View (POV)

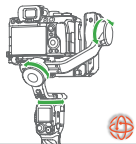

All three axes (pan, tilt, roll) follow the handle movement, allowing full-range camera rotation.

Suitable for action shots, immersive POV footage, or creative handheld-style cinematography.

Custom



Enables or disables the follow mode for each axis as needed.

All Lock Mode is enabled when the three axes are disabled. It is suitable for shots that require completely stable framing, such as static landscape, time-lapse, or precise composition.

Sport Mode (S)

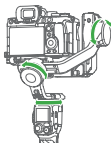

The follow speed of the gimbal increases for capturing quick-moving subjects and any fast paced action.

Ideal for capturing fast-moving scenes where quick adjustments are necessary, like sports, wildlife photography, or action shots.

Inception Mode (ICP)



360° infinite spin on pan axis while holding the gimbal horizontally.

Great for artistic shots, cinematic storytelling, or any situation where a dramatic perspective change can enhance the visual narrative.

6 AI Tracking

It is recommended to watch all the tutorial videos for the first time.



▶ Video Tutorial

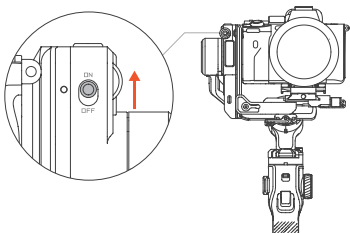

Before using the AI tracking and fill light functions, make sure to turn on the AI camera first.

- Tips**
- For optimal tracking performance, avoid use in strong backlighting or low-light environments.
 - The effective tracking range is 0.5–7 m (1.6–23 ft) for people and most objects. Larger targets, such as vehicles, can be tracked at distances of up to 15 m (49 ft). Smaller objects may require a shorter tracking distance for reliable performance.

6.1 Touchscreen Control

Slide right to view the AI Camera live feed on the remote touchscreen. Use touchscreen control to select a subject for tracking.

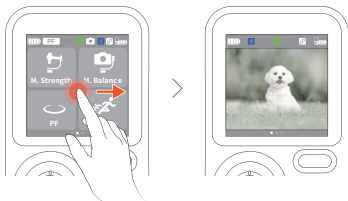

1. Double-tap the subject on the screen*. When the subject is highlighted with a green frame, the target is confirmed and tracking is activated.
*You can also drag on the screen to select the target first, then double-tap the subject for more precise tracking.
2. To switch targets during tracking, double-tap the new subject on the screen to lock onto it.
3. Triple-tap anywhere on the screen. When the subject is highlighted with a yellow frame, tracking has been paused.

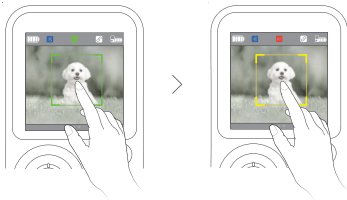

Green Frame: Target is selected and tracking is activated

Yellow Frame: Tracking has been paused

6.2 Button Control

Slide right to view the AI Camera live feed on the remote touchscreen. Use the trigger or the side button control to select a subject for tracking.

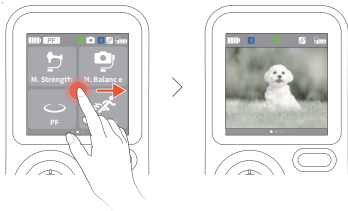

1. Drag select the subject on the touchscreen. When the subject is highlighted with a red frame, the target is selected.
2. Press once the trigger or the side button to activate or pause tracking.
3. When the subject is highlighted with a green frame, tracking is activated.
4. When the subject is highlighted with a yellow frame, tracking has been paused.

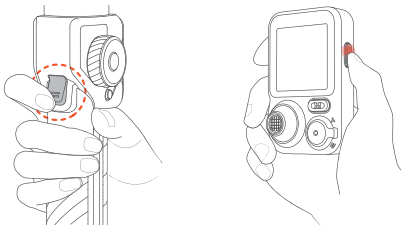



Red Frame:
Target is selected



Green Frame:
Tracking is activated



Yellow Frame:
Tracking has been paused

6.3 Gesture Control

Gesture Control

Gesture Recognition Distance: 0.5–5m (1.64–16.4ft)

Tracking Distance: 0.5–7m (1.64–23ft)

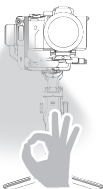
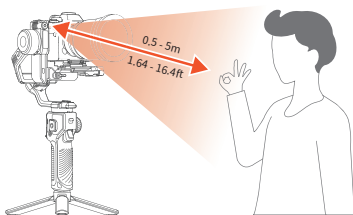

Start AI Tracking

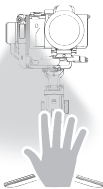

Stop AI Tracking

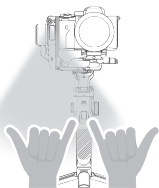

Shutter Control

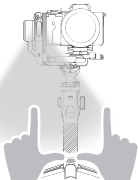

*Bluetooth connection needed.



Customized Composition

Customized Composition

The AI camera will keep you centered in your shot by default. You can adjust the framing using hand gestures:

1. Ensure the AI camera is on (indicator light solid green).
2. Perform the  gesture. The indicator will blink green rapidly.
3. Remain within the AI camera's range and move to your preferred position.
4. Repeat the  gesture to confirm and lock your new position.

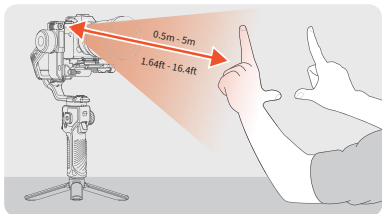

6.4 Live Feed Image Calibration

The image displayed on the touchscreen is the live feed from the AI Camera.

If the center of the AI Camera live feed does not align with the center of your shooting device's camera view, use Live Feed Image Calibration to adjust the composition.

1. Press and hold the side button on the controller to enter Live Feed Image Calibration.
2. Move the joystick left or right to adjust the live feed image on the touchscreen until it matches the composition of your camera view.
3. Press and hold the side button again to confirm and exit Live Feed Image Calibration.

6.5 Indicators

With two built-in indicators, the AI Camera provides status visibility from both sides.

Green: AI tracking is active.

Red: AI tracking is paused.

Green (Flashing): Custom composition is in progress.

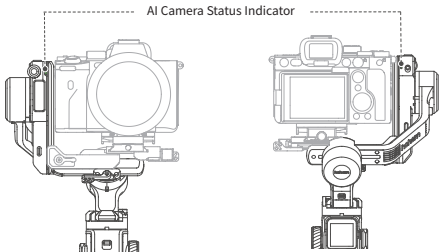

7 Hohem Joy App

7.1 Downloading

Scan the QR code or search "Hohem Joy" in App Store / Google Play to download the App.



7.2 Gimbal Connection







1. Attach your smartphone and turn on iSteady MT3 Pro.
2. Turn on Bluetooth on your smartphone.
3. Open the Hohem Joy App. Follow the on-screen instructions to complete the connection.

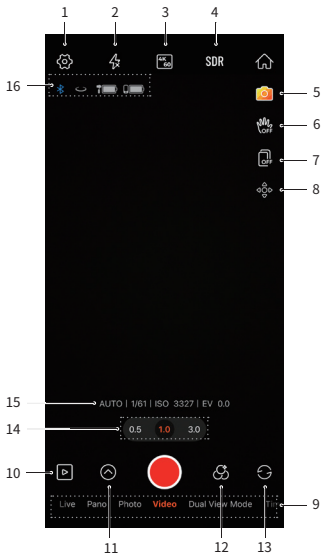



7.3 Camera Interface

Tips

The camera interface is subject to change due to updates of Hohem Joy App version.



- | | | | |
|----|---|----------------------------------|--|
| 1. |  | General Settings | Includes gimbal parameters, camera parameters, and gimbal information. |
| 2. |  | Flash | Adjust the flash. |
| 3. |  | Resolution and Frame Rate | Set resolution and video frame rate. |
| 4. | SDR | Color Space* | <p>Supports multiple color formats. Select SDR, HDR, Dolby Vision, P3 D65, or Apple Log as required for your workflow.</p> <p>*This feature is optimized for iOS devices, and the interface on Android devices may vary.</p> |
| 5. |  | Creative Studio | Provides shooting tutorials and ideas according to the situation or environment. |
| 6. |  | Gesture Control | <p>Use hand gestures to start/stop face tracking or control the shutter for photos and videos.</p> <p>*Object Tracking: Drag to select a target on the screen.</p> |
| 7. |  | Second Screen | Use another mobile device to remotely control the gimbal. |
| 8. |  | Gimbal Control | Use your mobile device to remotely control the gimbal, including Virtual Joystick, Motion Control, and Time-lapse. See 7.4 Gimbal Control . |
| 9. | | Shooting Modes | Tap to change the shooting mode. |

-
- | | | |
|-------|---|---|
| 10. |  Playback | Tap to preview photos and videos. |
| <hr/> | | |
| 11. |  Shooting Parameters Settings | Tap to access shooting parameters settings. |
| <hr/> | | |
| 12. |  Filter | Select a photo or a video filter. |
| <hr/> | | |
| 13. |  Front/Rear Camera Switch | Tap to switch between the front and rear cameras of your mobile phone. |
| <hr/> | | |
| 14. | Zoom | Use the zoom lever on the gimbal handle to zoom in or out, or tap the zoom bar on the screen to select a specific zoom ratio. |
| <hr/> | | |
| 15. | Shooting Parameters | Display the shutter speed, ISO, and EV values. |
| <hr/> | | |
| 16. | Gimbal Status | View the gimbal's Bluetooth connection status, current working mode, gimbal battery level, and smartphone battery level respectively. |
-

For more information, visit www.hohem.com, or scan the QR code to view tutorials.



 Video Tutorial

7.4 Gimbal Control

When the iSteady MT3 Series gimbal is connected to the Hohem Joy app, you can control gimbal movement using the virtual joystick for shooting. The speed and sensitivity of each axis can be individually adjusted within the app.

Time-lapse parameters can also be customized according to your shooting needs.

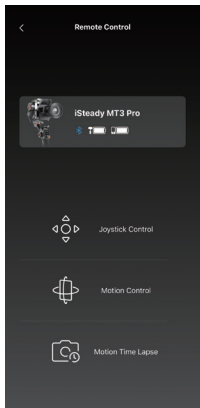
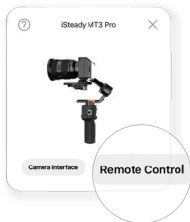

Joystick Control

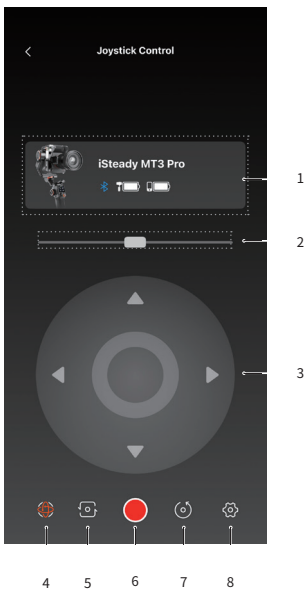

1. Gimbal Status	Display the current Bluetooth connection status, gimbal battery level, and remote controller battery level.
2. Roll Stick	Controls the roll axis movement of the gimbal using the virtual joystick.
3. Pan/Tilt Stick	Controls the pan and tilt axes movement of the gimbal using the virtual joystick.
4. Gimbal Working Mode	Switch between different gimbal working modes.
5. Pan Rotation 180°	Rotates the pan motor position by 180° .
6. Shoot/Record Button	Tap to take a photo or start/stop video recording*.
7. Recenter	Tap to recenter the gimbal.
8. Gimbal Settings	Tap to access additional gimbal settings.

*Make sure the camera and gimbal are properly connected using the camera control cable/via Bluetooth connection.

Motion Control

After enabling this feature, the gimbal movement can be controlled by tilting and rotating your mobile phone.

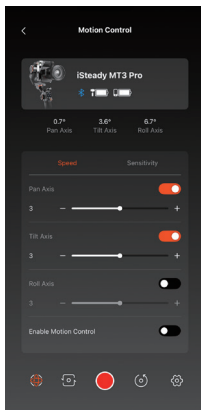

Adjust the speed and sensitivity of each gimbal axis using the control bars. Speed controls the rotational speed when the gimbal is operated remotely. Sensitivity determines how responsive each axis is to control input. Higher sensitivity values result in quicker, more responsive gimbal movement.

Motion Time Lapse

In Motion Time Lapse, you can customize the shooting duration and define a gimbal movement path based on your shooting needs.

The configured settings can also be saved as a custom template for quick access in future shoots.

After confirming the parameters, tap Start, and the gimbal will move automatically along the preset path for the specified duration.

*Make sure the camera and gimbal are properly connected using the camera control cable/via Bluetooth connection before using Motion Time Lapse.

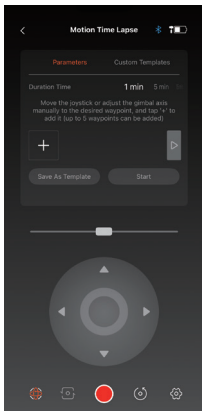

You can adjust the camera orientation by either pushing the joystick on the gimbal handle or tapping the virtual joystick icon in the app.

Motion Time Lapse supports up to five waypoints, allowing the camera to move smoothly between multiple positions during the Timelapse.

Set a Waypoint

Move the camera to the desired position.

Tap the "+" icon to confirm and add the waypoint.

To add additional waypoints, move the gimbal to the next position and tap the "+" icon again.

Edit Waypoints

Delete a waypoint: Select the waypoint and tap the "×" icon

Reset a waypoint: Select the waypoint, move the gimbal to the desired position, and tap the "✓" icon to confirm

After all waypoints are set, you can either tap Start to begin Motion Time Lapse, or save the current setup as a custom template for later use.

8 Specifications

Gimbal

Weight	Approx. 1070 g (2.36 lbs) *Tripod not included in the weight
Dimensions	Unfolded: 378 x 150 x 199 mm (14.9 x 5.9 x 7.8 in) Folded: 216 x 295 x 65 mm (8.5 x 11.6 x 2.6 in)
Maximum Load	2.5 kg (5.51 lbs)

Camera Compatibility	Height: ≤ 118.5 mm (≤ 4.67 in) Width: ≤ 149 mm (≤ 5.87 in) Depth (camera + lens): ≤ 225 mm (≤ 8.86 in)
-----------------------------	---

Phone Compatibility	Width: 58-98 mm (2.28-3.86 in)
----------------------------	--------------------------------

Battery Capacity	21700 li-ion, 7.4V/4350mAh/32.19Wh
-------------------------	------------------------------------

Operating Time	Approx. 20 hours (Balanced and stationary) Approx. 14 hours (With AI tracking) Approx. 8 hours (With AI tracking and fill light used simultaneously) *Data sourced from Hohem Laboratory
-----------------------	---

Charging Time	3.5 hours (5V=3A)
----------------------	-------------------

Controllable Angle	Pan: 360° Infinite Roll: -45° -45° Tilt: -188° -108°
---------------------------	--

Operating Temperature	-10° C-40° C (32 °F -104 °F)
------------------------------	------------------------------

Remote Controller

Battery Capacity	3.85V/240mAh/0.924Wh
-------------------------	----------------------

Remote Control Range	≤ 10 m (≤ 32.81 ft)
-----------------------------	----------------------

Wireless Video Transmission Range	≤ 10 m (≤ 32.81 ft)
--	----------------------

Touchscreen	1.4 inches
--------------------	------------

AI Camera

Pixel	2 MP
--------------	------

Gesture Recognition Distance	0.5-5 m (1.64-16.4 ft)
-------------------------------------	------------------------

Tracking Distance	0.5–7 m (1.64–23 ft) for people and most objects; up to 15 m (49.2 ft) for large targets (e.g., vehicles). *Smaller objects may require a closer distance.
--------------------------	---

Light Illuminance	Approx. 75 lux at 0.5 m (1.64 ft)
--------------------------	-----------------------------------

Light Power	2.5W
--------------------	------

RGB	Stepless RGB color and brightness control
------------	---

CCT	2700K, 3000K, 3500K, 4000K, 4500K, 5000K, 5500K, 6000K, 6500K
------------	---

9 Safety Guidelines

Disclaimer

Please read this Disclaimer carefully. By using this product, you accept its terms and acknowledge that you are solely responsible for your conduct and any consequences that arise from it. Use the product only for lawful purposes. Shenzhen Hohem Technology Co., Ltd. (referred to as 'Hohem') accepts no liability for misuse, damages, injuries, penalties, or legal issues related to the product and its accessories. Before each use, ensure your accessories are in proper condition; discontinue use if you find any damage or irregularities. Hohem reserves the right to interpret and revise these terms within the bounds of state laws.

Warning

1. Avoid any contact between the product and liquids. Never immerse it in water or expose it to moisture. Avoid using the product in the rain or in humid environments, as moisture may cause internal corrosion, which could lead to battery self-ignition or explosion.
2. In case of fire, quickly extinguish it using water, water mist, sand, a fire blanket, dry powder, or a carbon dioxide extinguisher. Choose the appropriate method based on the actual situation.
3. Store and operate the product within a temperature range of -10°C to 40°C (14° F to 104° F).
4. Do not disassemble the product in any way. Puncturing the battery during disassembly could cause electrolyte leakage, leading to fire or explosion. Also, avoid applying mechanical impact, squeezing, or throwing the product, and do not place heavy objects on it.
5. Do not heat the product. Do not place it in a microwave oven or pressure cooker. Keep the product away from heat sources such as stoves or heaters, and do not store it in a hot car.
6. Do not store the battery in a fully discharged state for an extended period, as this may lead to over-discharge, causing irreversible damage to the battery cells.

7. Use the original charging cable for charging.
8. Do not operate the gimbal without mounting a camera, as this may cause motor vibrations, damage, or equipment malfunction. Ensure that the camera is properly installed before use.

Note:

1. The iSteady MT3 Pro is a high-precision control device. Dropping it or subjecting it to external impacts may damage the iSteady MT3 Pro , leading to operational malfunctions.
2. Ensure that when the iSteady MT3 Pro is powered on, the gimbal rotates freely without being obstructed by external forces.
3. The iSteady MT3 Pro is not waterproof. Do not allow the iSteady MT3 Pro to come into contact with any liquids, nor use any cleaning liquids on it. It is recommended to clean the iSteady MT3 Pro with a soft, dry cloth.
4. When using the iSteady MT3 Pro, take precautions against dust and sand.
5. The iSteady MT3 Pro gimbal contains magnets. To avoid magnetization effects, keep it away from magnetic cards, IC cards, pacemakers, hard drives, RAM chips, and other devices that are susceptible to magnetic interference.
6. Use the tripod on a flat surface in a windless environment. Otherwise, there is a risk of it tipping over and being damaged.

10 Compliance Information

CE Statement

Hereby, [Shenzhen Hohem Technology Co., Ltd.] declares that the radio equipment type [HCG-MT3P, HRT-06] is in compliance with Directive 2014/53/EU. The full text of the EU declaration of conformity is available at the following internet address: www.hohem.com

RF exposure information: The EIRP power of the device at maximal case is below the exempt condition, 20mW specified in EN62479: 2010. RF exposure assessment has been performed to prove that this unit will not generate the harmful EM emission above the reference level as specified in EC Council Recommendation(1999/519/EC).

FCC Regulatory Conformance

This device complies with Part 15 of the FCC Rules. Operation is subject to the following two conditions:

- (1) This device may not cause harmful interference.
- (2) This device must accept any interference received, including interference that may cause undesired operation.

RF Exposure

The SAR limit adopted by FCC is 1.6 W/kg averaged over one gram of tissue. The highest SAR value reported to the FCC for this device type complies with this limit. The highest SAR value reported to the FCC for this device type when using in portable exposure conditions is 0.04 W/kg.

NOTE:

This equipment has been tested and found to comply with the limits for a Class B digital device, pursuant to part 15 of the FCC Rules. These limits are designed to provide reasonable protection against harmful interference in a residential installation.

This equipment generates uses and can radiate radio frequency energy and, if not installed and used in accordance with the instructions, may cause harmful interference to radio communications. However, there is

no guarantee that interference will not occur in a particular installation. If this equipment does cause harmful interference to radio or television reception, which can be determined by turning the equipment off and on, the user is encouraged to try to correct the interference by one or more of the following measures:

- Reorient or relocate the receiving antenna.
- Increase the separation between the equipment and receiver.
- Connect the equipment into an outlet on a circuit different from that to which the receiver is connected.
- Consult the dealer or an experienced radio/TV technician for help.

NOTE:

The manufacturer is not responsible for any radio or TV interference caused by unauthorized modifications to this equipment. Such modifications could void the user's authority to operate the equipment.

IC Regulatory Conformance

This device complies with CAN ICES-003 (B)/NMB-003(B).

This device complies with Industry Canada licence-exempt RSS standard(s).

Operation is subject to the following two conditions:

- (1) this device may not cause harmful interference, and
- (2) this device must accept any interference received, including interference that may cause undesired operation.

Cet appareil est conforme à la norme CAN ICES-003 (B)/NMB-003 (B).

Le présent appareil est conforme aux CNR d'Industrie Canada applicables aux appareils radio exempts de licence. L'exploitation est autorisée aux deux conditions suivantes :

- (1) l'appareil ne doit pas produire de brouillage, et
- (2) l'utilisateur de l'appareil doit accepter tout brouillage radioélectrique subi, même si le brouillage est susceptible d'en compromettre le fonctionnement.

RF Exposure

The SAR limit adopted by IC is 1.6 W/kg averaged over one gram of tissue. The highest SAR value reported to the IC for this device type complies with this limit. The highest SAR value reported to the IC for this device type when using in portable exposure conditions is 0.04 W/kg.

KC Compliance Notice

" 해당무선설비는 운용 중 전파혼선 가능성이 있으므로 인명안전과 관련된 서비스는 할수 없습니다."

" 해당 무선설비는 운용 중 전파혼선 가능성이 있음 "

ANATEL Statement

Este equipamento não tem direito à proteção contra interferência prejudicial e não pode causar interferência em sistemas devidamente autorizados. Para maiores informações, consulte o site da ANATEL – <https://www.gov.br/anatel>

This equipment is not entitled to protection against harmful interference and may not cause interference to properly authorized systems. For more information, see the ANATEL website – <https://www.gov.br/anatel>

WEEE Notice

1. Korrekte Entsorgung von Elektro- und Elektronikgeräten und Symbol der „durchgestrichenen Mülltonne“ Die durchgestrichene Mülltonne auf Elektroaltgeräten bedeutet, dass Sie gesetzlich verpflichtet sind, diese Geräte einer vom unsortierten Siedlungsabfall getrennten Erfassung zuzuführen. Die Entsorgung über die Restmülltonne, die gelbe Tonne oder den gelben Sack ist gesetzlich untersagt. Enthalten die Geräte Batterien, Akkumulatoren oder Lampen, die nicht fest verbaut sind, müssen diese vor der Entsorgung entnommen und getrennt als Gerätealtbatterien entsorgt werden.
2. Möglichkeiten der Rückgabe von Altgeräten Besitzer von Altgeräten können diese im Rahmen der durch öffentlich-rechtliche Entsorgungsträger oder bei den von Herstellern oder Vertreibern im

Sinne des Elektro Geingerichteten Rücknahmestellen abgeben, damit eine ordnungsgemäße Entsorgung der Altgeräte sichergestellt ist. Ein Onlineverzeichnis der Sammel- und Rücknahmestellen können Sie sich über die folgende Internetseite anzeigen lassen: <https://e-schrott-entsorgen.org/>

3. Datenschutz

Wir weisen alle Endnutzer von Elektro- und Elektronikaltgeräten darauf hin, dass Sie für das Löchen personenbezogener Daten auf den zu entsorgenden Altgeräten selbst verantwortlich sind.

1. Correct disposing of waste electrical and electronic equipment (WEEE) and symbol of the "crossed-out wheeled bin" The crossed-out wheeled bin on WEEE means that you are obliged by law to dispose of this equipment separately from the unsorted municipal waste collection system. Disposing of it in the residual waste bin, the yellow bin or yellow bag for recyclable materials is legally prohibited. If the equipment contains portable batteries, accumulators or lamps that are not permanently installed, these must be removed before disposing of the product and be disposed of separately as waste portable batteries.
2. Ways of returning waste electrical and electronic equipment Owners of waste electrical and electronic equipment can return them to those facilities for returning or collecting waste electrical and electronic equipment set up and provided by the public-sector waste disposal authorities or alternatively with collection points installed by producers, retailers or distant sellers to ensure that the waste electrical and electronic equipment is disposed of correctly. The following link leads to an online registry of the available collection and take-back sites: <https://e-schrott-entsorgen.org/>
3. Data privacy
We should point out to all end-users of waste electrical and electronic equipment that they themselves are responsible for deleting all personal data from the waste electrical and electronic equipment to be disposed of.

低功率射頻器材技術規範

取得審驗證明之低功率射頻器材，非經核准，公司、商號或使用者均不得擅自變更頻率、加大功率或變更原設計之特性及功能。

低功率射頻器材之使用不得影響飛航安全及干擾合法通信；經發現有干擾現象時，應立即停用，並改善至無干擾時方得繼續使用。

前述合法通信，指依電信管理法規定作業之無線電通信。低功率射頻器材須忍受合法通信或工業、科學及醫療用電波輻射性電機設備之干擾。

部件名称	有害物质					
	铅 (Pb)	汞 (Hg)	镉 (Cd)	六价铬 (Cr ⁶⁺)	多溴联苯 (PBB)	多溴二苯醚 (PBDE)
线路板	×	○	○	○	○	○
外壳	×	○	○	○	○	○
液晶屏 (如有)	×	○	○	○	○	○
金属部件 (铜合金)	×	○	○	○	○	○
内部线材	×	○	○	○	○	○
其他配件	×	○	○	○	○	○

本表格依据 SI/T 11364 的规定编制。

O: 表示该有害物质在该部件所有均质材料中的含量均在 GB/T 26572 规定的限量要求以下。

X: 表示该有害物质至少在该部件的某一均质材料中的含量超出 GB/T 26572 规定的限量要求

(产品符合欧盟 ROHS 指令环保要求)



